

RICCAR®

CARPET EXTRACTOR

model RCE

Owner's Manual



- IMPORTANT SAFETY INSTRUCTIONS**.....2
 - Grounding instructions.....3
 - Description of the extractor.....4
 - Before using your extractor for the first time5

- Operation**
 - While operating the machine.....6
 - Cleaning with accessory tools7
 - Draining the recovery tank.....8
 - Draining the solution tank8

- Maintenance and Care**
 - Filter maintenance.....8
 - Extractor maintenance.....9

- Problem Solving Guide**
 - Troubleshooting10
 - Helpful hints11

- Owner's Information**.....12

- Warranty**.....13

IMPORTANT SAFETY INSTRUCTIONS

This machine is intended for household use. It is designed to clean carpet and upholstery in an indoor environment and is not constructed for any other use. Use only recommended cleaning solutions and accessory tools.

All operators must read, understand and practice the following safety precautions.

WARNING: The manufacturer cannot accept responsibility for damage caused when the appliance is not used according to the instructions, or for uses other than those for which it was intended.

To reduce the risk of fire, electric shock or injury:

Do not operate machine:

- Unless trained and authorized.
- Unless operator manual is read and understood.
- In flammable or explosive areas.
- Unless cord is properly grounded.
- With damaged cord or plug.
- If not in proper operating condition.
- In outdoor areas.
- In standing water.
- With the use of an extension cord.

Before operating machine:

- Make sure all safety devices are in place and operate properly.

When using machine:

- Do not run machine over cord.
- Do not pull machine by plug or cord.
- Do not pull cord around sharp edges or corners.
- Do not unplug by pulling on cord.
- Do not stretch cord.
- Do not handle plug with wet hands.
- Keep cord away from heated surfaces.
- Report machine damage or faulty operation immediately.
- Follow mixing and handling instructions on chemical containers.

Before leaving or servicing machine:

- Turn off machine.
- Unplug cord from wall outlet.

When servicing machine:

- Unplug cord from wall outlet.
- Avoid moving parts. Do not wear loose jackets, shirts, or sleeves.
- Use manufacturer supplied or approved replacement parts.

WARNING: Hazardous voltage. Shock or electrocution can result. Always unplug machine before servicing.

WARNING: Flammable materials can cause an explosion or fire. Do not use flammable materials in tank(s).

WARNING: Flammable materials or reactive metals can cause an explosion or fire. Do not pick up any of these items and materials.

Grounding Instructions

This carpet extractor must be grounded. If it should malfunction or break down, grounding provides a path of least resistance for electric current to reduce the risk of electric shock.

This carpet extractor is equipped with a cord having an equipment-grounding conductor and grounding plug. The plug must be plugged into an appropriate outlet that is properly installed and grounded in accordance with all local codes and ordinances.

This carpet extractor is for use on a nominal 120-volt circuit and has a ground plug (see illustration). Make sure the carpet extractor is connected to an outlet having the same configuration as the plug. No adapter should be used with this carpet extractor.

WARNING – Improper connection of the equipment-grounding conductor can result in the risk of electric shock. Check with a qualified electrician or service person if you are in doubt as to whether the outlet is properly grounded. Do not modify the plug provided with the carpet extractor – if it will not fit the outlet, have a proper outlet installed by a qualified electrician.

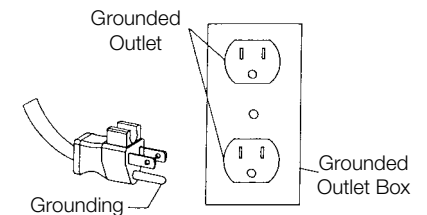

SAVE THESE INSTRUCTIONS.

Description of the Extractor

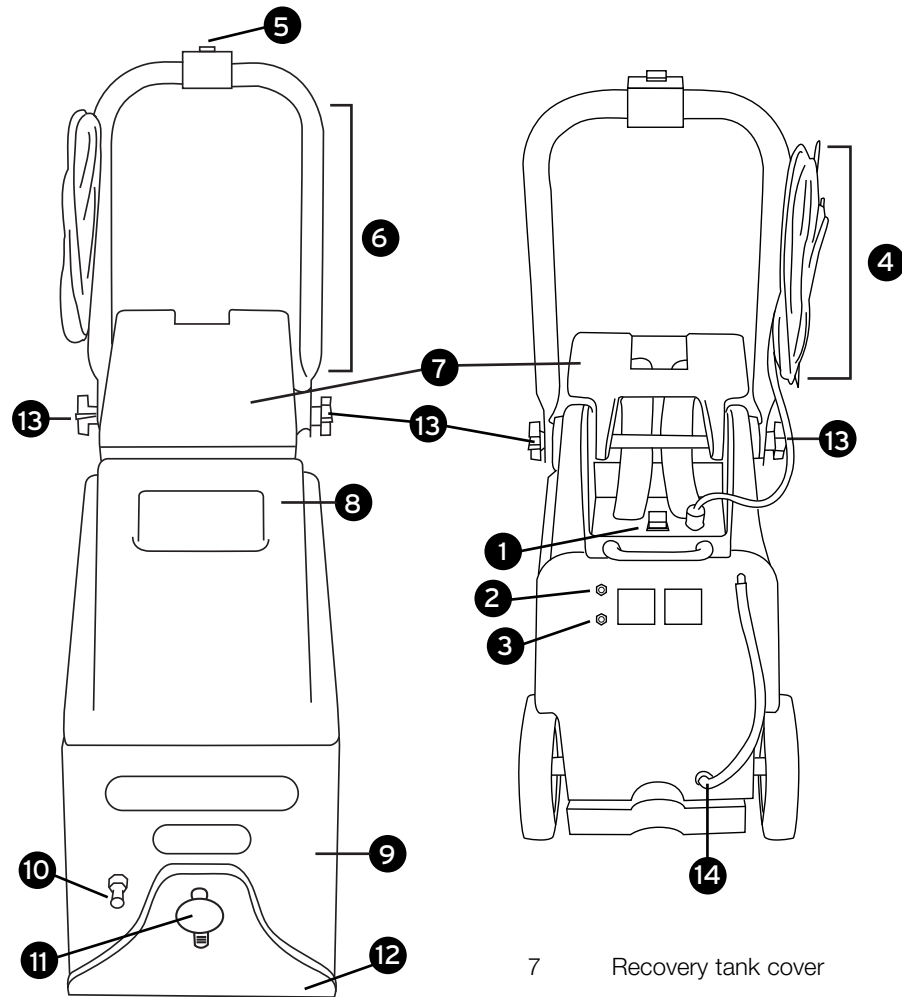

- | | | | |
|---|----------------------------|----|--------------------------|
| 1 | Main on / off power switch | 9 | Solution tank |
| 2 | Pump reset button | 10 | Accessory hose coupler |
| 3 | Brush reset button | 11 | Accessory hose port |
| 4 | Power cord hooks | 12 | Nozzle |
| 5 | Solution button | 13 | Folding handle lock knob |
| 6 | Folding handle | 14 | Solution tank drain hose |
| | | 7 | Recovery tank cover |
| | | 8 | Recovery tank |

Before Using Your Extractor for the First Time

- The machine is shipped fully assembled and is ready for use.
- Adjust handle from transport position. To adjust, while standing behind the machine lift handle to desirable operating height. Turn right knob forward while turning left knob backward to tighten handle in operating position (fig 1).
- Hinge open cover and remove recovery tank from machine. Make sure the float shut-off screen and filter are in place before use.
- Using a clean bucket, fill solution tank with 15L (4 gal) of hot water, 60°C (140°F) maximum (fig 2). Observe solution tank hose at rear of machine when filling. The hose indicates the amount of water in solution tank. Do not use recovery tank to fill machine. Use a clean bucket.
- Replace recovery tank and close cover after filling.
- Plug machine's power cord into a grounded wall outlet.

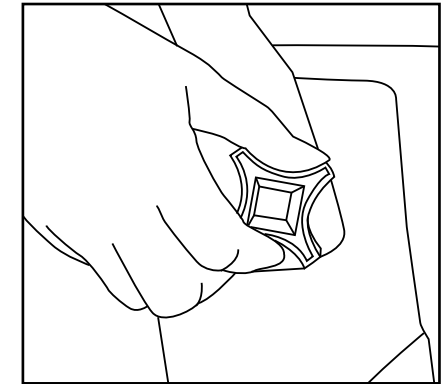

Figure 1

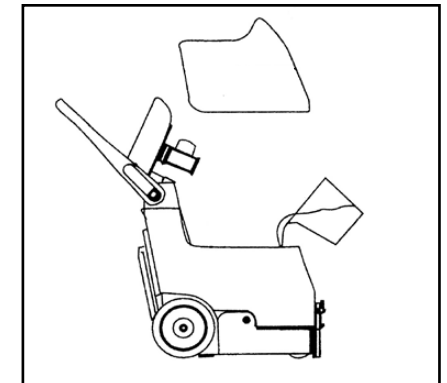

Figure 2

Attention: Do not use recovery tank to fill solution tank. Residual dirt or debris could cause damage to solution pump.

Warning: Flammable materials can cause an explosion or fire. Do not use flammable materials in tank(s).

For Safety: When using machine, follow mixing and handling instructions on Riccar chemical containers.

Note: Use Riccar Extractor Detergent only.

Operation

For Safety: Do not operate machine unless operator manual is read and understood.

- Vacuum carpet thoroughly and remove other debris.
- Turn main power switch on.
- To begin cleaning carpets, push button on handle with thumbs and slowly pull machine backward (fig 1).

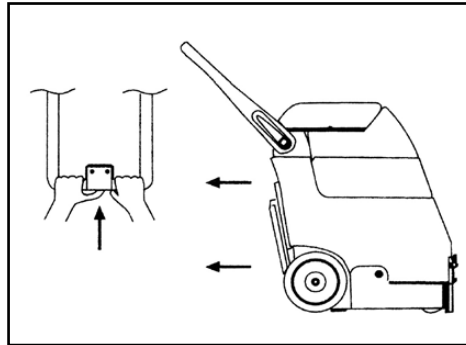

Figure 1

- Release handle button at end of path and continue to pull machine backward to pick up excess solution.
- Tip machine back on wheels and push machine forward to begin next path.

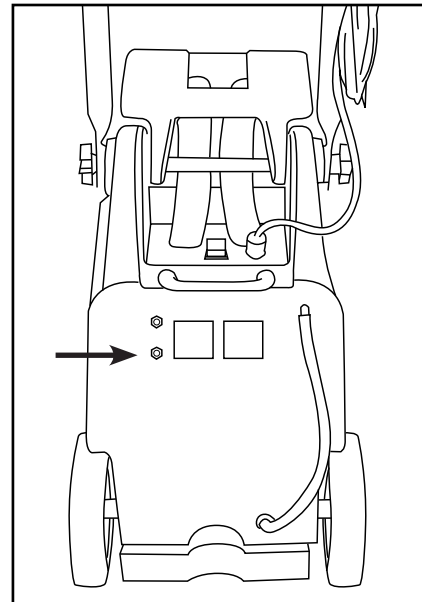

Figure 2

While operating the machine

- Overlap each path by 2 inches.
- Work away from outlet and power cord to prevent cord damage.
- Periodically check for excessive foam buildup in recovery tank.

Attention: Excessive foam buildup will not activate the float shut-off screen.

- If brush stops, the circuit breaker may have been tripped. Unplug power cord and check brush for obstruction. Push brush reset button to resume (fig 2).

- To clean heavily soiled areas, repeat cleaning path from a different direction.

- When the unit is no longer dispensing cleaning solution or the recovery tank is full, empty the recovery tank and fill solution tank (see "Draining Tanks").

Attachment Cleaning

- Connect accessory hose to hose coupler (fig 1) and hose port (fig 2) located at front of machine.
- Connect accessory tool to coupler and hose cuff on the other end of the hose (fig 3).
- Turn main power switch on.
- To clean stairs or upholstery, squeeze trigger on accessory tool to release solution. Release trigger and continue to pull tool over surface to pick up excess solution.
Note: When cleaning upholstery, always check cleaning instructions sewn in furniture by the manufacturer.
- After cleaning, squeeze trigger for five seconds after turning main power switch off to relieve water pressure from tool before disconnecting hose.

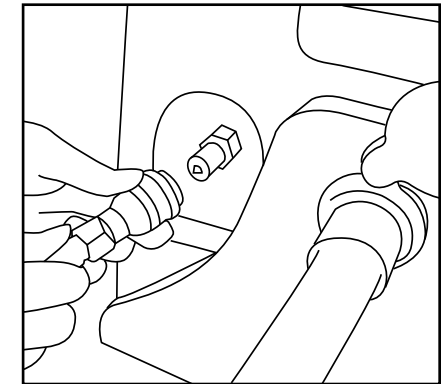

Figure 1

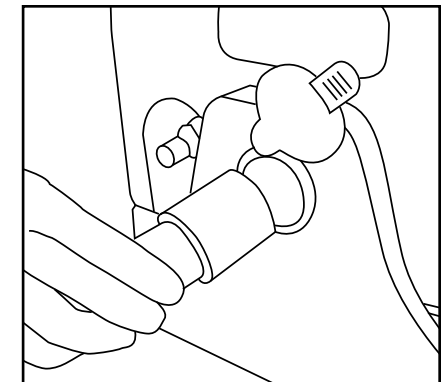

Figure 2

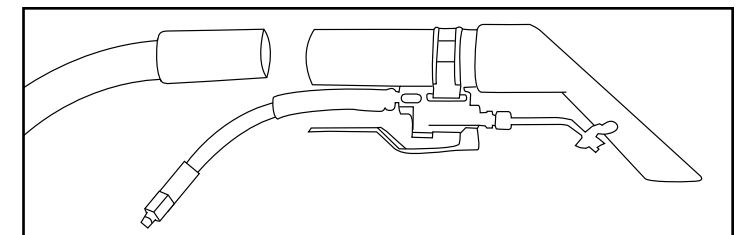

Figure 3

Draining Tanks

For Safety: When servicing machine, unplug cord from wall outlet.

Draining recovery tank

- Turn machine off and unplug power cord.
- Hinge open cover, lift recovery tank out and empty.

Note: Make sure to rinse out recovery tank after each use. Do not use this tank to fill machine with cleaning solution.

Draining solution tank

- Remove solution tank drain hose at rear of machine and empty remaining solution (fig 1).
- Replace drain hose (fig 2).

Filter Maintenance

To clean the external filter, remove the recovery tank and locate the filter. Remove the filter screws, grasp the inner handles and pull out the filter (fig 3). Rinse the filter inside and out. You can then replace the filter by snapping the filter back into the solution tank and reattaching the screws.

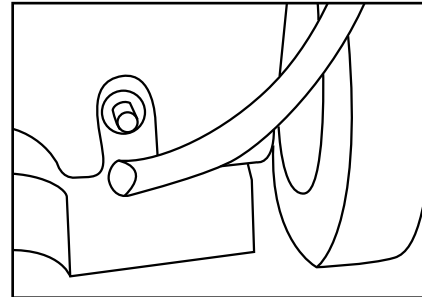

Figure 1

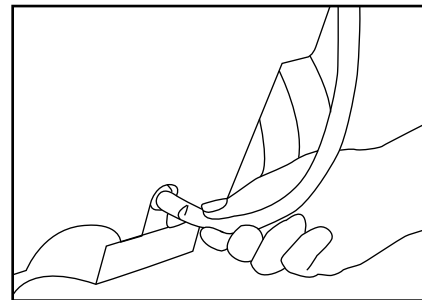

Figure 2

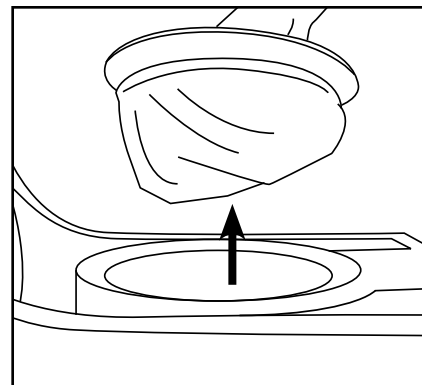

Figure 3

For Safety: When servicing machine, unplug cord from wall outlet.

Regular Maintenance Tips

- Empty and rinse out recovery tank thoroughly.
- Remove float shut-off screen from hinged cover above the recovery tank cover and clean (fig 1).
- Drain remaining water from solution tank (see “Draining Tanks”).
- Clean solution tank external filter. (see “Filter Maintenance”).
- Remove any entangled carpet fibers and debris from brushes underneath machine (fig 2).
- Remove any debris lodged in nozzle.
- Wipe off power cord and check for damage, replace if necessary. Coil cord neatly around cord hooks after use.

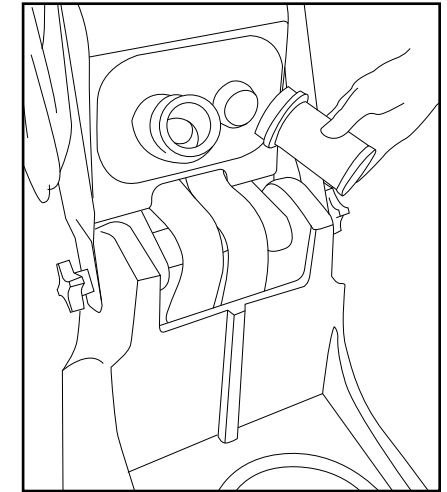

Figure 1

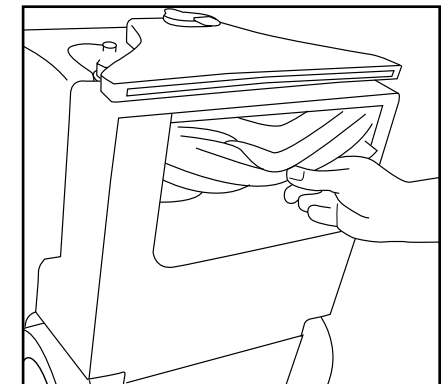

Figure 2

Problem Solving Guide

Troubleshooting

Please check each item below if you have trouble with the carpet extractor. Unplug the carpet extractor from the power supply before servicing.

Problem	Cause	Solution
Machine does not operate	Extractor not plugged in	Plug in unit.
	Main on/off switch not turned to the on position.	Turn machine on.
	Building circuit breaker tripped.	Unplug machine from wall outlet. Check and reset circuit breaker in building. Plug in machine and turn on to operate. If building circuit breaker trips again, discontinue use.
Brush motor does not operate	Brush motor circuit breaker tripped.	Let motor cool and reset brush motor breaker button at rear of machine.
Solution pump does not operate	Solution pump circuit breaker tripped.	Let pump cool and reset pump breaker button at rear of machine.
	Button on handle not pushed.	Push solution button on handle.
Poor solution pick-up	Pulling machine too fast.	Slow down cleaning process.
	Clogged float shut-off screen.	Open recovery tank cover and clean lint off screen.
	Accessory tool vacuum hose port cover is loose or missing.	Check vacuum hose port cover.

Any other service should be done by an Authorized Service Representative.

Service 1-888-6-RICCAR

To locate your nearest retailer, visit our website at www.riccar.com

Problem Solving Guide

Helpful Hints

Please check each item below if you have trouble with the carpet extractor. Unplug the carpet extractor from the power supply before servicing.

Problem	Cause	Solution
If machine is leaking	The drain hose is loose.	Check to ensure the solution tank drain hose (clear tube) is securely connected.
If you hear a louder, higher-pitched motor noise	Solution tank is empty.	Empty recovery tank, refill solution tank and make sure the ball in the float shut-off screen is moving freely, not jammed.
There is no fluid in the clear drain hose, or there is no solution on your carpet	Solution tank is low or empty.	Refill the solution tank.
If there is no solution on your carpet	The two spray tips on the bottom of the extractor are clogged.	Locate the two spray nozzles on the bottom of the machine (they are located up and behind the brushroll). Rotate each nozzle 1/4 turn, and pull the nozzle off the machine. Poke a straight pin through the hole to unclog the tip. Remove debris. Rinse nozzle, then reattach.

Any other service should be done by an Authorized Service Representative.

Service 1-888-6-RICCAR

To locate your nearest retailer, visit our website at www.riccar.com

Owner's Information (keep this for your records)

The model and serial number of this product may be found on the back of the unit. You should note the model and serial number of your carpet extractor in the spaces provided below, and retain this book as a permanent record of your purchase.

Date of purchase _____

Serial number _____

Model number _____

Purchased from:

Store name _____

Address _____

City, State, Zip _____

Telephone _____

Specifications

Model: RCE
Rating: 120V/60Hz
Amps: 12

Warranty

What is Covered:

This warranty covers any defects in material and workmanship in your new Riccar carpet extractor and applies exclusively to the original purchaser.

How Long Coverage Lasts:

Warranty coverage for the Riccar carpet extractor lasts two years. Warranty for the Riccar extractor tanks lasts ten years.

What is Not Covered:

- Damage to the extractor which occurs from neglect, abuse, alterations, accident, misuse or improper maintenance.
- Normal replacement items: cords and filters.

What Riccar Will Do:

This warranty provides, at no cost to you, all labor and parts to place this carpet extractor in correct operating condition during the warranted period.

How to Get Service:

Warranty service can only be obtained by presenting the extractor to an Authorized Riccar Retailer. A proof-of-purchase and product serial number will be required before service is rendered. To locate your nearest Riccar Retailer, please call 1-888-6-RICCAR or visit the Riccar website at www.riccar.com.

THIS WARRANTY IS EXCLUSIVE AND IN LIEU OF ANY AND ALL OTHER WARRANTIES WHETHER WRITTEN, ORAL, EXPRESSED OR IMPLIED, (INCLUDING ANY WARRANTY OF MERCHANTABILITY OR FITNESS FOR A PARTICULAR PURPOSE). THIS WARRANTY DISCLAIMS LIABILITY FOR INCIDENTAL, OR CONSEQUENTIAL DAMAGES.

How State Law Applies:

This warranty gives you specific legal rights, and you may also have other rights which vary from state to state.

RICCAR®
www.riccar.com